

Solid Bottom Tray Type KH

150

Material: Hot Dip Galvanized I.S 918 (H.D.G.A.F) Standard: Din 17100 ST 37.2 3 [mm]

Horizontal Bend

Tray: Din 17100 ST 37.2

Model	R _{mm}	Price ₪
BKH - 400	600	341
BKH - 500	600	349
BKH - 600	600	375
BKH - 700	600	402
BKH - 800	600	423
BKH - 900	600	483
BKH -1000	600	501

Galvanized 3mm

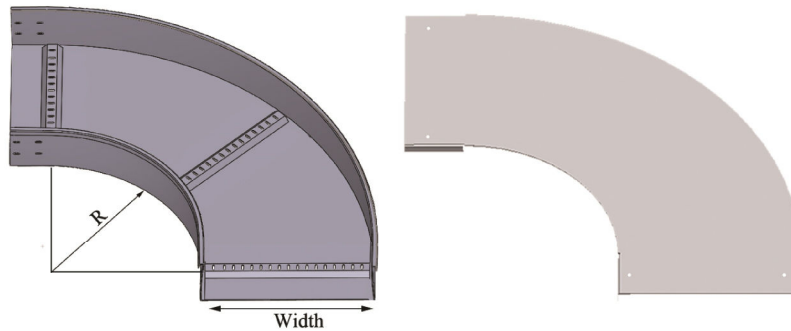

Cover: EN-10346 G-275

Model	Price ₪
CBKH - 400	198
CBKH - 500	211
CBKH - 600	238
CBKH - 700	274
CBKH - 800	294
CBKH - 900	316
CBKH -1000	335

Galvanized 1.5mm

Customize radius is available by request
Width apply to horizontal bend model [mm]

T Branch

Tray: Din 17100 ST 37.2

Model	R _{mm}	Price ₪
TKH - 400	600	476
TKH - 500	600	488
TKH - 600	600	514
TKH - 700	600	571
TKH - 800	600	589
TKH - 900	600	596
TKH -1000	600	664

Galvanized 3mm

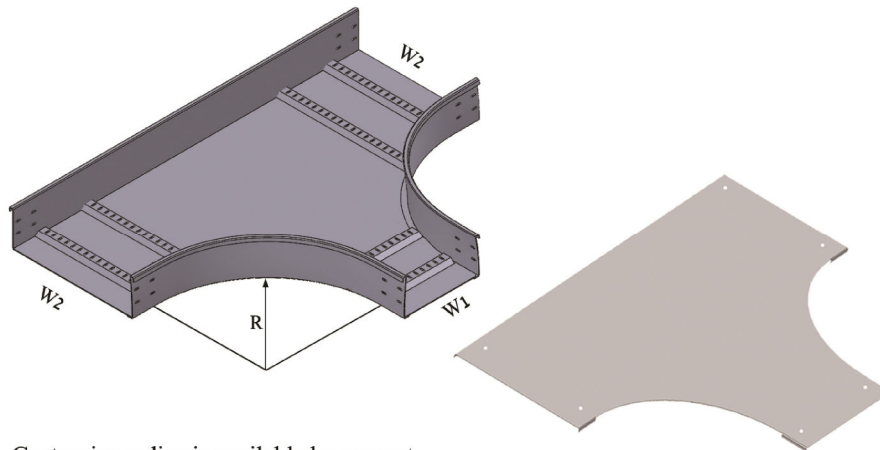

Cover: EN-10346 G-275

Model	Price ₪
CTKH - 400	315
CTKH - 500	338
CTKH - 600	366
CTKH - 700	393
CTKH - 800	426
CTKH - 900	457
CTKH -1000	500

Galvanized 1.5mm

Customize radius is available by request
Specify W1 & W2 measurements [mm]

Cross Over X

Tray: Din 17100 ST 37.2

Model	R _{mm}	Price ₪
XKH - 400	600	638
XKH - 500	600	678
XKH - 600	600	704
XKH - 700	600	730
XKH - 800	600	748
XKH - 900	600	824
XKH -1000	600	850

Galvanized 3mm

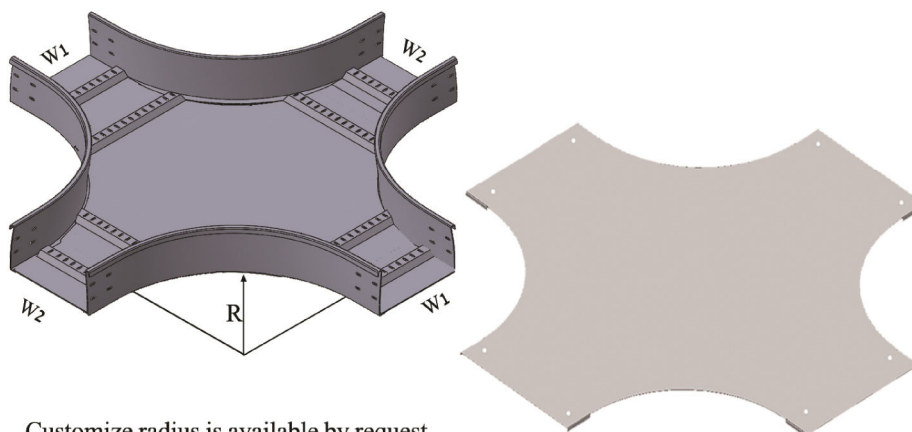

Cover: EN-10346 G-275

Model	Price ₪
CXKH - 400	433
CXKH - 500	465
CXKH - 600	504
CXKH - 700	542
CXKH - 800	588
CXKH - 900	611
CXKH -1000	672

Galvanized 1.5mm

Customize radius is available by request
Specify W1 & W2 measurements [mm]



☎ 04-8411142, 04-8414834

☎ 04-8414528

🌐 www.naor.co.il

✉ naor_ltd@netvision.net.il

Copyright © all rights reserved Naor L.T.D

- 33 -

